

DrayTek

Vigor2862 Series

VDSL2 Security Firewall

- Fail-over and Load Balancing effectively work with any WAN combination
- USB ports for 3G/4G USB mobile, FTP server and network printer
- Web Content Filter support keywords, URL and HTTP/HTTPS content filtering
- 32 VPN Tunnels (including 16 SSL VPN tunnels)
- Capable VPN Backup & Load Balance
- External Device Management for VigorAP series/VigorSwitch series



Vigor2862 series security firewall routers have built-in VDSL2/ADSL2+ modem, plus a second Ethernet WAN port for Cable or Satellite broadband, and 2 USB ports for 3G/4G mobile broadband access. With the multi-WAN accesses, Vigor2862 series router supports multi-wan fail-over and load-balancing for USB WANs, VDSL2/ADSL2+, FTTx broadband. If your premise can not subscribe fixed broadband line, you can rely on the 3G/4G LTE (connected to USB WANs) as primary connection.

The specifications cover many functions that are required by modern day businesses, including secure but easy to apply firewall, comprehensive VPN capability, Gigabit LAN ports, USB ports for 3G/4G mobile dongles, FTP and Samba server and network printers, VLAN for flexible workgroup management, and much more.

The Vigor2862 Series provides you with different levels of security including authentication (802.11x), encryption (up to WPA2) and methods such as DHCP fixing to restrict access to authorized users only and Mac address locking. Through the Web User Interface (WUI), you can see how many and which clients are currently connected and how much bandwidth usage they consume.

The wireless VLAN function lets you isolate wireless clients from each other or from the "wired" LAN. You can set certain password for your guest to let guests access your WLAN with "password". The Web-portal setup (log-in) can let you have four rules along with 4 multiple SSIDs. When users connect to your WLAN, they will be directed with your log-in screen before any Internet access is permitted. You can customize your Web-portal setup (log-in) page.

The multiple SSID features can let your network administrator set up four common or distinct virtual wireless access points. e.g. those with SSID1 can access to your ERP, those with SSID2 can surf internet. With the button of WPS (Wi-Fi protected setup), your client PC can get its security keys by pressing the WPS button on front of the router. There are several wireless channels for you to choose the best channel where is with the least congested wireless traffic.

DrayTek Vigor2862 series are implemented with AP Management to facilitate deployment of multiple VigorAP 810 SOHO-level access point and VigorAP 902 enterprise-level access point. You can have overview over the status of multiple APs. For multiple wireless clients, to apply the AP Load Balancing to the multiple APs will manage wireless traffic with smooth flow and enhanced efficiency.

For remote teleworkers and inter-office links, Vigor2862 Series provide up to 32 simultaneous VPN tunnels (such as IPSec/PPTP/L2TP protocols) for secure data exchange and communication. With a dedicated VPN co-processor, the hardware encryption of AES/DES/3DES and hardware key hash of SHA-1/MD5 are seamlessly handled, thus maintaining maximum router performance. Teleworkers can be authenticated directly with your LDAP server if preferred. The Vigor2862 Series are equipped physical DSL port and Gigabit Ethernet port for WAN load-balancing and backup. The VPN trunking (VPN load-balancing and VPN backup) are hence implemented on Vigor2862 Series. With VPN trunking, you can create multiple WAN connections to a remote site in order to increase bandwidth.

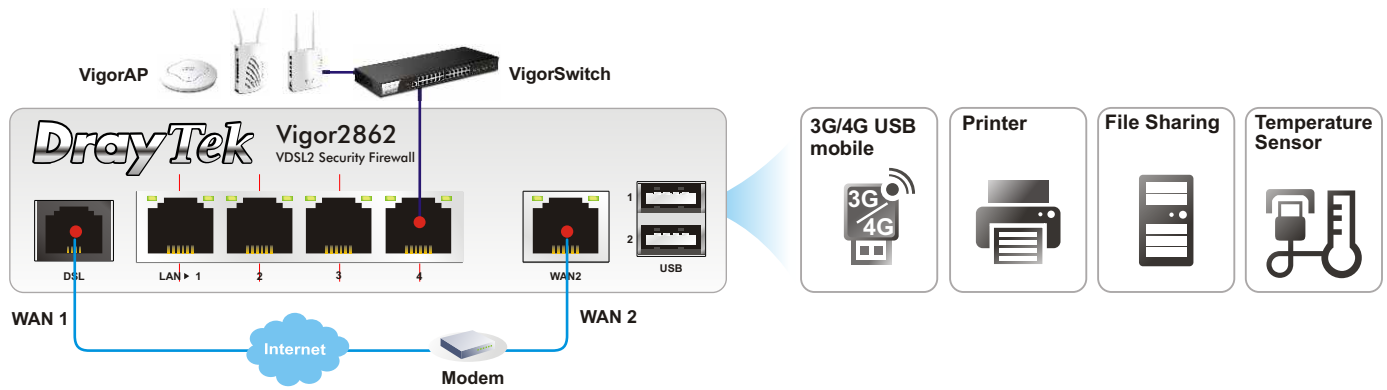

Connectivity

VDSL2/ADSL2/2+

- ITU-T G.993.2 (VDSL2)
- ITU-T G.992.1/3/5 (ADSL1/2/2+) Annex A & Annex B
- DSL Forum Performance Specification: ADSL TR-048/67, TR-100; VDSL: WT-114
- Erasure Decoding, Increased Interleaver Depth and Re-transmission
- EFM (IEEE 802.3 ah)
- VDSL/Bonding Profile: up to 30a

Ethernet WAN

- IPv4 - DHCP Client, Static IP, PPPoE, PPTP, L2TP, 802.1q Multi-VLAN Tagging
- IPv6 - Tunnel Mode: TSPC, AICCU, 6rd, Static 6in4
Dual Stack: PPP, DHCPv6 Client, Static IPv6
- WAN Connection Fail-over
- WAN Budgets
- Load Balance/Route Policy

Ethernet LAN

- IPv4/IPv6 DHCP Server
- Static Routing/RIP
- Multiple Subnet
- Port/Tag-based VLAN

USB

- 3G/4G Modem as WAN3/WAN4 /Printer Server/File Sharing /Temperature Sensor

VPN

- Up to 32 VPN Tunnels
- Protocol : PPTP, IPsec, L2TP, L2TP over IPsec
- Encryption : MPPE and Hardware-based AES/DES/3DES
- Authentication : MD5, SHA-1
- IKE Authentication : Pre-shared Key and Digital Signature (X.509)
- LAN-to-LAN, Teleworker-to-LAN
- DHCP over IPsec
- IPsec NAT-traversal (NAT-T)
- Dead Peer Detection (DPD)
- VPN Pass-through
- VPN Wizard
- mOTP
- Supports 16 SSL VPN Tunnels
- VPN Trunk: VPN Backup and Load Balance

Management

System Maintenance

- HTTP/HTTPS with 2-level Management (Admin/User)
- Logging via Syslog
- SNMP Management MIB-II (v2/v3)
- CLI (Command Line Interface, Telnet/SSH)
- Administration Access Control
- Web-based Diagnostic Functionality
- Firmware Upgrade via TFTP/HTTP /TR-069
- CWMP Support (TR-069/TR-104)
- LAN Port Monitoring

Network Management

- Bandwidth Management by session /bandwidth
- User Management by Time/Data Quota
- LAN DNS and DNS Proxy/Cache
- Dynamic DNS
- IGMP Snooping/Proxy v2 and v3
- QoS (DSCP/Class-based/4-level priority)
- Guarantee Bandwidth for VoIP
- Support Smart Monitor
- Central AP Management
- Central VPN Management
- Support Switch Management

Security

- Multi-NAT, DMZ Host, Port-redirection and Open Port
- Object-based Firewall, Object IPv6, Group IPv6
- MAC Address Filter
- SPI (Stateful Packet Inspection) (Flow Track)
- DoS/DDoS Prevention
- IP Address Anti-spoofing
- E-mail Alert and Logging via Syslog
- Bind IP to MAC Address
- Time Schedule Control
- Content Security (IM/P2P, URL, Keywords, Cookies,...)

WLAN

- Multiple SSID
- Security (Open, 64/128-bit WEP, WPA/WPA2, 802.1x)
- Hidden SSID
- Wireless Rate Control by SSID
- Wireless VLAN
- Wireless LAN Isolation
- MAC Address Access Control
- Access Point Discovery
- Wireless Client List
- WDS (Wireless Distribution System)
- WMM (Wi-Fi Multimedia)

Hardware Interface

- 1 x VDSL2/ADSL2/2+ WAN Port (WAN1), RJ-11 for Annex A/RJ-45 for Annex B
- 1 x 10/100/1000Base-Tx, RJ-45 (WAN2)
- 4 x 10/100/1000Base-Tx LAN Switch, RJ-45 (Configurable Physical DMZ on Port4)
- 2 x Detachable Antennas (n Model)
- 4 x Detachable Antennas (ac Model)
- 2 x USB Host 2.0
- 1 x Factory Reset Button
- 1 x Wireless On/Off/WPS Button (n/ac model)

	WLAN	
	VDSL Bonding	2.4 GHz 5 GHz
Vigor2862 ac		•
Vigor2862 n		•
Vigor2862 Bn	•	•
Vigor2862 B	•	
Vigor2862		